



POINTE
AT PRIMUS

Architectural Guidelines

Single Family Homes

Revised April 11, 2019

Pointe at Primus Architectural Guidelines

Table of Contents

Introduction	2
A. Architectural Review Committee Guidelines and Procedures	
I. Who and What is the Architectural Review Committee	2
II. Purpose	2
III. Scope of Architectural Review Committee	2
IV. Steps for Obtaining Architectural Review Committee Approval	3
V. Enforcement	3
VI. Fines	3
VII. Appeals Process	4
B. Landscape Standards	
I. Front and Side Treatment	4
II. Rear Area Treatment	4
III. Irrigation	4
IV. Maintenance	4
V. Tree Removal	5
C. Wall and Fence Standards	
I. Style	5
II. Position	5
III. Maintenance	6
D. Outbuilding Standards	
I. Placement	6
II. Height, Size, and Materials	6
E. Exterior Modifications	
I. Additions and Alterations to a Dwelling	7
II. Porches, Sunrooms and Decks	7
III. Temporary Structures	7
IV. Lighting	7
V. Monuments, Sculptures, and Flag Poles	7
VI. Swimming Pool	7
VII. Docks	7
VIII. Play Equipment	8
IX. Outside Antennas and Satellite Dishes	8
F. Additional Flatwork	
I. Driveways	8
II. Patios	8
G. Signs	
I. Types	9
II. Style	9
III. Placement	9
H. Recreational Boat and Vehicle Procedures	
I. Storage and Parking	9
Appendix	
A. Suggested Landscaping	10
B. Architectural Review Committee Application	11
C. For Sale Sign Details	12
D. Fence Options	13-16

INTRODUCTION

Architectural Guidelines are put into place to ensure a cohesive design for a neighborhood without sacrificing the individuality of each home. The standards aid the development of a desirable and attractive neighborhood. They ensure, enhance, and protect the value of all the homes within Pointe at Primus. This document is meant to be a supplement to the Covenants and Restrictions for the neighborhood, but the Covenants and Restrictions always supersede these guidelines. The guidelines will aid the reader in understanding those elements that are important to the integrity of an individual home, as well as to the manner in which that home compliments the overall harmony of the neighborhood. No action taken by the Architectural Review Committee (ARC) shall entitle any person to rely thereon with respect to conformity with the laws, regulations, codes or ordinances of local, state, or federal governments.

A. ARCHITECTURAL REVIEW COMMITTEE GUIDELINES AND PROCEDURES

I. Who and What is the Architectural Review Committee

The Architectural Review Committee shall be the governing body charged with promoting and maintaining a high level of design, quality, harmony and conformity throughout Pointe at Primus. The Declarant controls the Architectural Review Committee until the time of turnover; afterwards the elected board from the homeowner's association takes control. No improvements of any kind shall be erected, placed, or maintained, and no alteration or modification of any improvements in Pointe at Primus shall be made without approval of the Architectural Review Committee.

II. Purpose

The Architectural Review Committee is established to provide a system of review for the construction or modification of all improvements within the Project. The goal of the Architectural Review Committee is to review the application of plans and specifications to determine the compliance with the standards set forth by the Covenants and Restrictions. The Board strives to ensure the communities are attractive by maintaining the principles set forth in the Covenants and Restrictions. The Architectural Review Committee does not assume responsibility for the technical aspects, structural aspects, or safety of the design. Nor does the Architectural Review Committee assume responsibility for compliance with local codes, ordinances, or laws.

III. Scope of Architectural Review Committee

The Architectural Review Committee reviews, approves, and/or disapproves all plans and submissions solely on the basis of aesthetic standards, harmony of location, external structure and design relating to surrounding topography and the overall benefit or detriment to the overall Project. The ARC will take into account aesthetic aspects of architectural design, placement of buildings, color schemes, exterior finishes, and materials used. The Architectural Review Committee is not responsible for structural safety of the improvement or the conformance with building codes. The ARC holds the right to refuse any submittals that are not suitable or desirable to the overall aesthetics of the neighborhood. The Board of Directors also reserves the right to grant variances to

these standards on the basis necessity or unusual conditions. The Architectural Review Committee reserves the right to inspect all aspects of the improvements after the construction process has been completed. Declarant improvements are not subject to the ARC approval and are deemed to conform to the plan of development for Pointe at Primus.

IV. Steps for Obtaining Architectural Review Committee Approval

1. Plans for improvements must be submitted to the Architectural Review Committee to include all aspects of the improvement along with the proper application form.
2. Applicant must submit a plot plan of the lot showing the location of the improvement.
3. The Architectural Review Committee may require the submission of additional information and materials as needed to supplement the application.
4. All approvals or disapprovals will be written and sent to each respective Applicant.
5. Applicants may submit improvement plans to the Architectural Review Committee before the closing of a home to ensure the home will fit all the needs of the homeowner.

V. Enforcement

The Architectural Review Committee, Declarant, the Board of Director or designee reserves the right of entry and inspection of any lot or portion of Property to determine the existence of improvement that violates the standards set forth by both this document and the Covenants and Restrictions. Except in emergency situations, any exercise of entry and inspection will follow at least a twenty-four hour notice to the Owner. The Board of Directors is empowered to enforce the provisions set forth in both this document and the Covenants and Restrictions by any legal action, and in the event it becomes necessary to resort to the legal system all fees are incurred to the prevailing party. The cost of removal of unapproved improvements will also be incurred to the Owner.

VI. Fines

A system of reasonable enforcement policies, which includes fines, has been put into place to allow the Association to enforce the standards set forth in both this document and the Covenants and Restrictions. This fine structure is subject to change if the Association considers the current system ineffective.

Prior to imposition of any fine, the Architectural Review Committee, Declarant, the Board of Director or designee shall serve the alleged violator with written notice including:

- The nature of the alleged violation;
- The proposed sanction to be imposed;
- A statement that the alleged violator may present a written request for a hearing to the Board within 15 days of the notice;
- A statement that the proposed sanction shall be imposed as contained in the notice unless a request for a hearing is received by the Board, within such time period.

VII. Appeals Process

Unless a timely request for a hearing is received by the Board, the sanction stated in the notice shall be imposed. The Board of Directors may suspend the proposed sanction if the violation is cured or if the resident begins the cure within 15 days. The Board of Directors is not obligated to suspend the sanction. Any suspension does not waive the right to sanction future violations of the same or other violations.

B. LANDSCAPE STANDARDS

The general character of any home is greatly determined by the elements of its surroundings. Proper selection and placement of plant materials is extremely important in establishing the overall setting of the home. The landscape guidelines promote continuity in the landscape where individual lots relate to one another while at the same time allowing for individuality of each lot.

I. Front and Side Treatment

Emphasis should be placed on proper proportion rather than quantity or size of plant material. Try to select plants that will give year-round bloom. Small plots of contoured grass provide year-round color and low maintenance. A list of suggested trees and plants is available in Appendix A.

II. Rear Area Treatment

The configuration of Pointe at Primus's lots allows for a variety of landscaping treatments. If appropriately planned, much of the area can be kept in its natural state if desired. Structures such as decks lend themselves to more formal landscaping. In some cases the over shaded condition will limit the use of sod; however, keep in mind that grass offers many advantages such as: year-round color and low maintenance. There are many natural shrubs available at low cost that requires little maintenance. A list of suggested trees and plants is available in Appendix A.

III. Irrigation

The Architectural Review Committee must approve irrigation system location before it is installed.

IV. Maintenance

Each Owner is responsible for maintaining, in a healthy condition, all natural and introduced vegetation on their lot. Removal of dead or diseased plant material must be done on a regular basis in accordance with the best practices for the plant material involved. Each Lot must have grass lawn that must be mowed and maintained on a regular basis. The grass lawn must be edged and maintained at a height that is pleasing to the ARC. The Architectural Review Committee reserves the right of landscape inspections for each Owner in the Project. If an Owner fails to maintain all plant materials within a lot in the manner described above, the Architectural Review Committee may remedy such failure by whatever methods it deems necessary and appropriate. The Owner shall reimburse the Architectural Review Committee for all expenses incurred by performing the duties described above.

V. Tree Removal

An Owner must obtain written approval from the Architectural Review Committee before any tree over six inches in diameter is removed from any lot. Tree removal guidelines are put into place to keep the Pointe at Primus Community as natural as possible, along with developing a low-country feel. Additionally, an Owner will need to check with the Town of Mount Pleasant and Charleston County to get approval for the removal of any tree before applying to the ARC.

C. WALL AND FENCE STANDARDS

Walls and fences serve several useful purposes. First and foremost, they delineate property lines between neighbors and between the public and private realm. Behind the house, fences and walls serve as a privacy screen, to keep pets at bay, or to form a spatial relationship for the courtyard garden. Walls and fences can take an infinite number of forms. Another option is a living wall of hedges or simply larger landscaping grasses. The Standards published by the Association may contain specifications for the materials, design, and location of fences, including, but not limited to, the location, number and design of the gates. Fence styles and locations allowed on Lots for Pointe at Primus are listed below. The Architectural Review Committee must approve all fences, fence styles, and fence locations before beginning installation. Appendix D shows recommended fence styles, colors, specifications, and materials.

I. Style

Four-foot wooden picket and six-foot privacy fences will be utilized in Pointe at Primus, and it is preferred that the fencing remain natural, treated with an ARC-approved stain, or painted Charleston Green. The recommended specifications and colors for these fences are listed in Appendix D. An ARC application must be approved prior to the fence being stained or painted. Pond lots must utilize a four foot fence design, so as to not obstruct views of the pond. The Architectural Review Committee recommends fence uniformity between neighbors to help maintain an aesthetically pleasing neighborhood. It is recommended that natural barriers such as landscaping be utilized in lieu of fences.

II. Position

Please note that fences may not be built in either Right of Ways or General Utility Easements without proper approval from the utility company(s). Additionally, fences are not permitted in a drainage easement without written approval from the Town of Mount Pleasant.

- It is required that the fence be built on the rear and side property lines.
- The fence may not extend past 15 feet from the rear corner of the house that is closest to the street.
- If there is an existing fence, it is required that the fence constructed secondly tie into the existing fence. In the event that the Board grants a variance that the latter fence is not required to be attached to the first fence, the Owner who constructed their fence secondly will be responsible for maintaining the yard between the fences.
- Fences on corner lots must be at least 18 feet from the back of curb. The Board reserves the right to modify this criterion if necessary.

III. Maintenance

The Owner of a Lot upon which a fence or wall is installed shall be solely responsible for providing and maintaining access to and from the rear yard of such lot. The Architectural Review Committee recommends refraining from placing fences in drainage or utility easements. In the event a fence is placed upon a drainage or utility easement, it is the Owner's responsibility to comply with all municipality regulations and restrictions. Any fence placed in an easement can and may be removed for improvements or repairs to the easements, and the replacement cost of the fence will be at the Owner's expense. In general, any fence installed upon a Lot shall be designed and used in a manner that will allow access to and from the rear yard of such Lot to allow the Architectural Review Committee to perform any of its obligations or exercise any of its rights pursuant to this document that require the ARC to have access to the rear portion of such Lot and to allow public utility companies to inspect, maintain and repair any utility facilities located within the boundary of the Lot.

All fences must be maintained and kept as new. If the fence is not maintained to the standards of the Architectural Review Committee it will be cause for a monetary fine and other remedies afforded the Board in the governing documents for the Association.

D. OUTBUILDING STANDARDS

Another important characteristic of Pointe at Primus is the option for outbuildings at the rear of the home. An outbuilding is defined as a detached structure from the main house, and is instead for smaller uses like equipment sheds or small workshops. In each case, materials used shall mimic that of the primary structure (i.e. the siding and roofing of the house). To be granted approval for an outbuilding, a fence must also be constructed previously, or a fence request must be submitted with the outbuilding request.

I. Placement

Placement of the outbuilding in relation to the Dwelling is critical to the formation of a spatial layout of the lot. The Architectural Review Committee must approve the placement of the outbuilding in relation to the lot layout. Please submit a plot plan with house and outbuilding location with application.

II. Height, Size, and Materials

Outbuildings should be compatible with the architectural style of the main house, but appear secondary in massing, scale, material, and detail. Height and size must be proportional to that of the house and lot. The recommended size for an outbuilding is 10' length by 12' width by 8' height. The material used for the outbuilding must be the same as the house. The Architectural Review Committee must approve all aspects of the outbuilding.

E. EXTERIOR MODIFICATION STANDARDS

Exterior modifications help make each home more individualized. Each Owner can modify his or her home based on the guidelines set forth in this document.

I. Additions and Alterations to a Dwelling

No Dwelling shall be enlarged by any addition thereto or to any part thereof, and no Owner shall make any improvement, addition, or alteration to the exterior of his Dwelling, including, without limitation, the painting, staining, or varnishing of the exterior of the Dwelling or re-roofing with shingles of a different color or material, without the prior written approval of the Architectural Review Committee, which may withhold approval for purely aesthetic reasons. Structural additions must be within all building setbacks and outside of utility and drainage easements.

II. Porches, Sunrooms, and Decks

The size and design of porches, decks, and sunrooms should be architecturally compatible with the Dwelling. The Architectural Review Committee must approve all plans before construction begins. Space below decks and sunrooms should be screened with lattice, shrubbery or other means appropriate to the house design.

III. Temporary Structures

No tents, trailers, shacks or other temporary buildings or structures shall be constructed or otherwise placed upon the Property except in connection with construction, development, leasing or sales activities permitted by the Architectural Review Committee or performed by Declarant. No temporary structure may be used as a Dwelling. No garden shed, storage shed, outbuilding, play structure, or other permanent structures, which are detached from the Dwelling, shall be constructed or placed upon the Property unless approved by the Architectural Review Committee.

IV. Lighting (Security)

Exterior lighting must be limited to areas within the building envelope. Exterior lighting shall be located so as not to result in excessive glare or interfere with the privacy of nearby Dwellings. Floodlights must be hooded and pointed in a downward position so as not to create a light nuisance. An exterior lighting plan with locations is required for approval by the Architectural Review Committee.

V. Monuments, Sculptures, and Flag Poles

The Architectural Review Committee must approve all monuments, sculptures, yard art, and flag poles that the Owner plans to place on the lot. Monuments, sculptures, yard adornment, and art of any kind are discouraged in front or side yards. Sculptures and yard art shall not exceed 3' in height.

VI. Swimming Pools

The Architectural Review Committee must approve all pool sizes, shapes, and layouts prior to installation. No above ground pools will be permitted anywhere in the development. It is the responsibility of the Owner to obtain all required permits from the governing municipality. An approved fence must be applied for, approved, and constructed along with a pool.

VII. Docks

No private docks are allowed in Pointe at Primus.

VIII. Play Equipment

Elements of a planned park or playground, swing sets and similar outdoor play areas, structures and equipment, must be located where they will have a minimum impact on adjacent lots and where they will be best screened from general public view. Play equipment must be located in the middle half of the rear of the lot on the non-street side. The play equipment must not exceed 8 feet in height, not including playset roof/canopy. Any proposed play equipment to be placed in the yard must be approved by the Architectural Review Committee. Natural wood play equipment is the only material approved for play structures. Brightly colored and plastic play equipment is not permitted, and may be declined by the Architectural Review Committee. A fence must be constructed before play structures will be permitted by the Architectural Review Committee. No trampolines are allowed in the Pointe at Primus Community. Basketball goals must be stored out of view when not in use.

IX. Outside Antennas and Satellite Dishes

No Owner may erect or maintain a television or radio receiving and transmitting antenna, satellite dish, or similar apparatus or equipment unless such equipment is: less than two feet in diameter; the apparatus is screened from public view and located behind the Dwelling either in the rear yard or affixed on the rear roofline; the apparatus is not visible from any point while standing along the property boundary line in the front of the Dwelling that abuts or is adjacent to a street, right-of-way or sidewalk; and the Architectural Review Committee has approved of the apparatus, its location, and the type of screen. All efforts must be made to screen the apparatus from view including the use of approved shrubbery.

If the signal cannot be obtained from one of the specified locations, a letter from the provider proving this must be submitted to the Board with the ARC request.

F. ADDITIONAL FLATWORK

I. Driveways

No additional driveways can be added to lots without specific approval by the Architectural Review Committee. If additions are approved they must be constructed of concrete that exactly matches that which is present. A two-foot minimum setback should be maintained from all property lines. Encroachments on the setback will be reviewed on a case-by-case basis by the Architectural Review Committee, and should be submitted to the governing municipality.

II. Patios

Any patio additions must be approved by the Architectural Review Committee.

G. SIGNS

In an effort to enhance the appearance of the Pointe at Primus Community, only certain types of signs will be permitted. This will promote a sense of consistency and enhance the general appearance of the community.

I. Types

The only type of sign permitted for a period longer than twenty-four hours in the Pointe at Primus Community is that which advertises a house is “For Sale.” The Architectural Review Committee for Pointe at Primus has produced a template for which all “For Sale” signs must match. This is shown in Appendix C. “For Rent” signs will not be permitted either in the yard or within the Pointe at Primus Community.

II. Style

Sign details are located in Appendix C.

III. Placement

The sign should be placed in the front center yard of the lot.

H. RECREATIONAL BOAT AND VEHICLE PROCEDURES

I. Storage and Parking

The storage of a boat, camping trailer, recreational vehicles or similar equipment is allowed in an enclosed garage provided the garage door remains closed. No overnight parking of the boat, visible from the street, is permitted. **If the boat is visible from behind the fence or the garage, it is not permitted by the Association and will be cause for monetary fines.**

APPENDIX A

Suggested Landscaping

Canopy Trees	Understory Trees	Buffer Shrubs	Ornamental Shrubs	Ground Cover/Vines	Turf
Red Maple	Cocas Palm	Sasanqua Camellia	Edward Goucher	Akebia	Bermuda Centipede Saint Augustine
Red Sunset Maple	Eastern Redbud	Eleagnus	Abelia	Weeping Love	
October Glory Red Maple	Flowering Dogwood	Burning Bush	Sherwood Abelia	Grass	
River Birch	Carolina Silverbell	Euonymus	Purple leaf	Winter creeper	
Heritage River	East Palatka Holly	Forsythia	Japanese	English Ivy	
Pecan	Foster Holly	East Palatka Holly	BACAerry	Hypericum	
Deodar Cedar	Hume Holly	Foster Holly	Harrington Plum-	Candytuft	
Green Ash	Savannah Holly	Hume Holly	Yew	Kadsura	
Japanese Gingko	Nellie Stevens	Savannah Holly	Cotoneaster	Liriope	
Moraine Honey locust	Holly	Dwarf Buford Holly	Daylily	Miscanthus	
Shademaster Honey locust	Natchez Crepe	Buford Holly	Carissa Holly	Mondo Grass	
Black Walnut	Myrtle (White)	Nellie Stevens Holly	Dwarf Horned	Fountain Grass	
Yellow Poplar	Potomac Crepe	Yaupon Holly	Holly	Asiatic Jasmine	
Sycamore	Myrtle (Medium Pink)	Anise	Juniper	Confederate	
Southern Red Oak	Muskogee Crepe	Pfizer Juniper	Sergeants Juniper	Jasmine	
Water Oak	Myrtle (Lavender)	Japanese Privet	Creeping Juniper		
Willow Oak	Catawba Crepe	Japanese Privet	HACAor Dwarf		
Shumard Oak	Myrtle (Dark Purple)	Variegated Chinese Privet	Nandina Dwarf		
Live Oak	Tuscarora Crepe	Maiden Grass	Pittosporum		
Scarlet Oak	Myrtle (Dark Pink)	Japanese Silver Grass	Dwarf Indian		
Laurel Oak	Saucer Magnolia	Wax Myrtle	Hawthorn		
Bald Cypress	Myrtle (Dark Pink)	Nandina			
Brasswood	Saucer Magnolia	Oleander			
Winged Elm	Sweet bay Magnolia	Fortunes Tea Olive			
Drake Chinese Elm	Flowering Crabapple	Fragrant Tea Olive			
Breen Vase Zelcova	Wax Myrtle	Pittosporum			
	Pistachio	Variegated Pittosporum			
	Cherry Laurel	Formosa Firethorn			
	Purple Leaf Plum	Majestic Beauty			
	Bradford Pear	Hawthorn			
	Aristocrat Pear	Japanese Cleyera			
	Palmetto				
	Windmill Palm				
	Chaste				

APPENDIX B

Architectural Review Committee Application

Please contact the property management company for the current application.

APPENDIX C

For Sale Sign Details

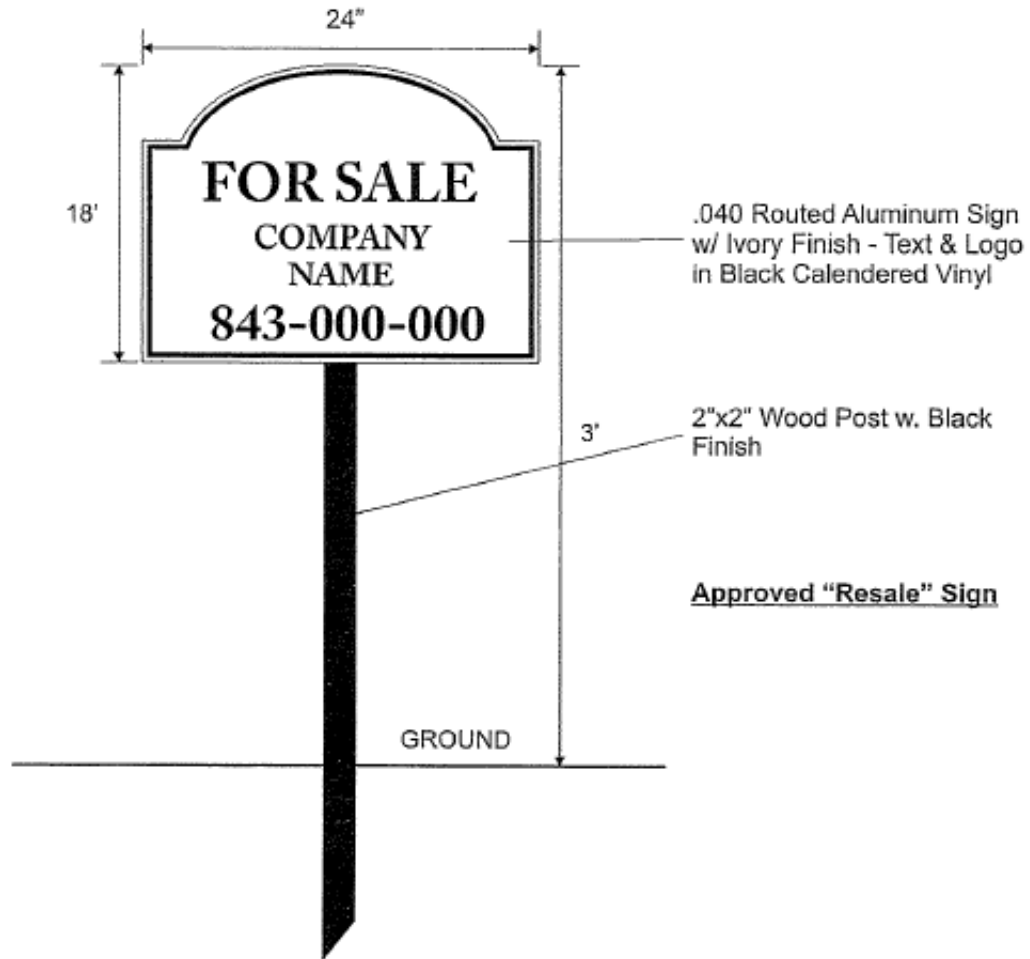

To obtain your approved signage please visit atlas signs at:

<https://www.goatlas.com>

APPENDIX D

Fence Options

Four-Foot Wooden Pickets
Natural, Treated w/Approved Stain*, or Painted Charleston Green

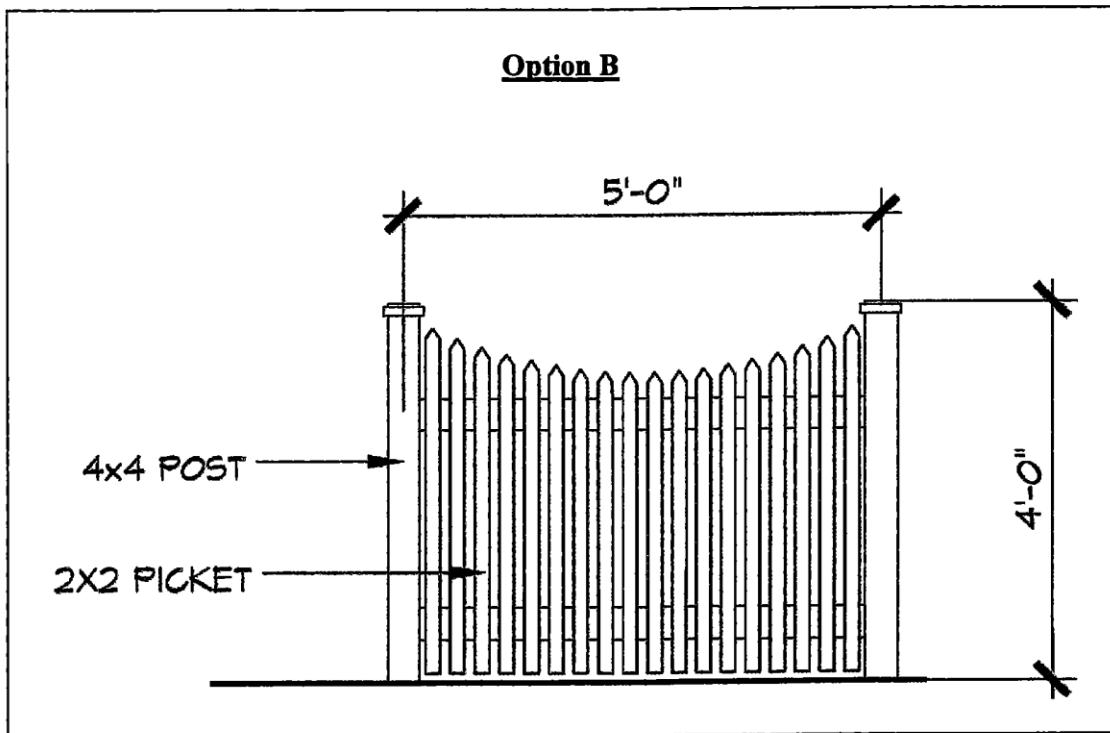
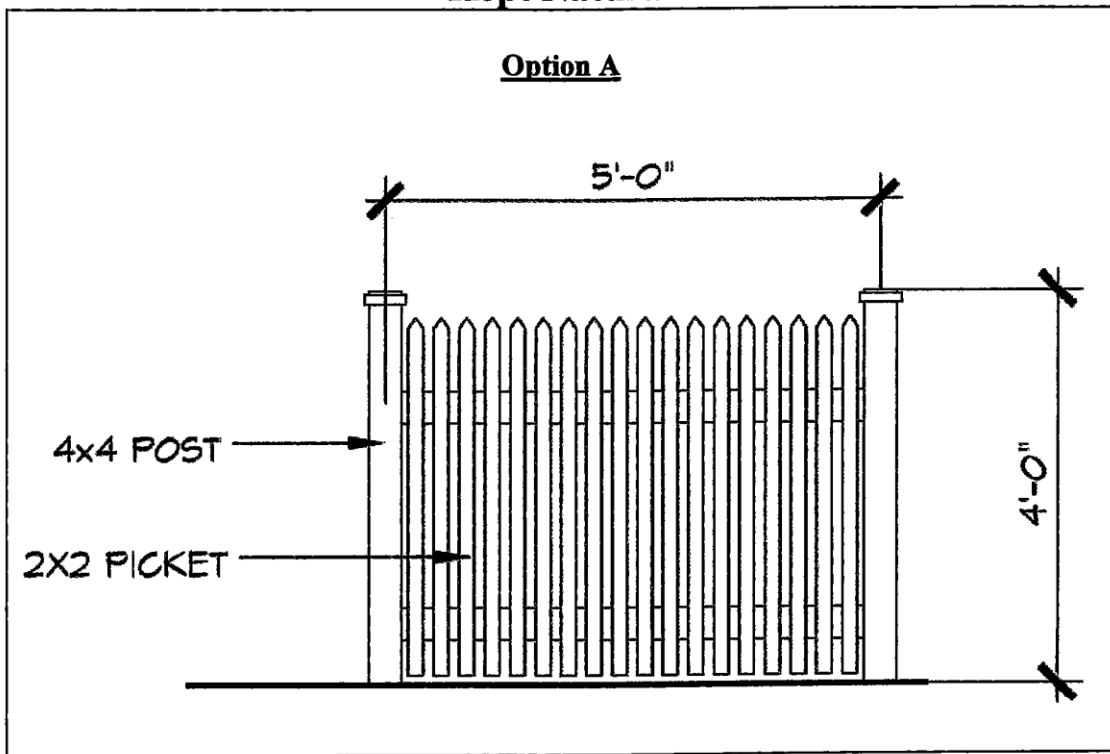

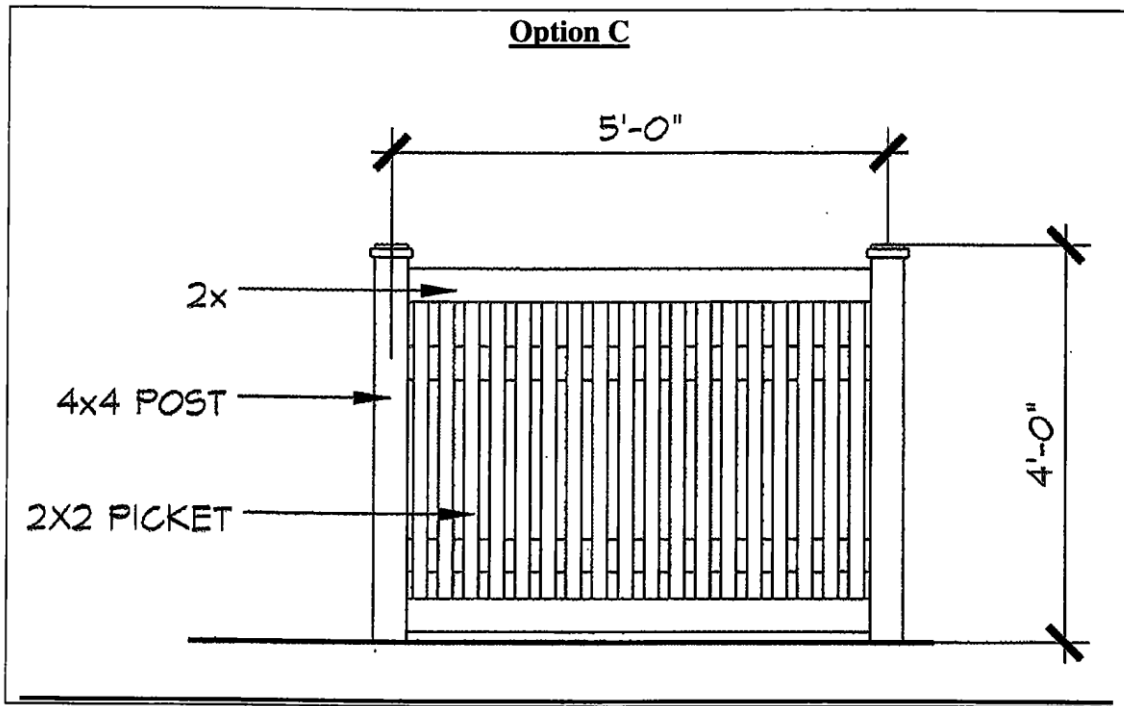

*Approved stains include the following from Sherwin Williams: SW 3503 White Birch, SW 3505 Yankee Barn, SW 3507 Riverwood, SW 3508 Covered Bridge, SW 3509 Baja Beige, SW 3521 Crossroads, SW 3540 Mountain Ash. Note: all stains are semi-transparent.

Six-Foot Privacy Fence
Natural, Treated w/Approved Stain*, or Painted Charleston Green

Permitted on Lots not located on a Pond.

*A six-foot shadow box fence is also permitted in the
Pointe at Primus Community.*

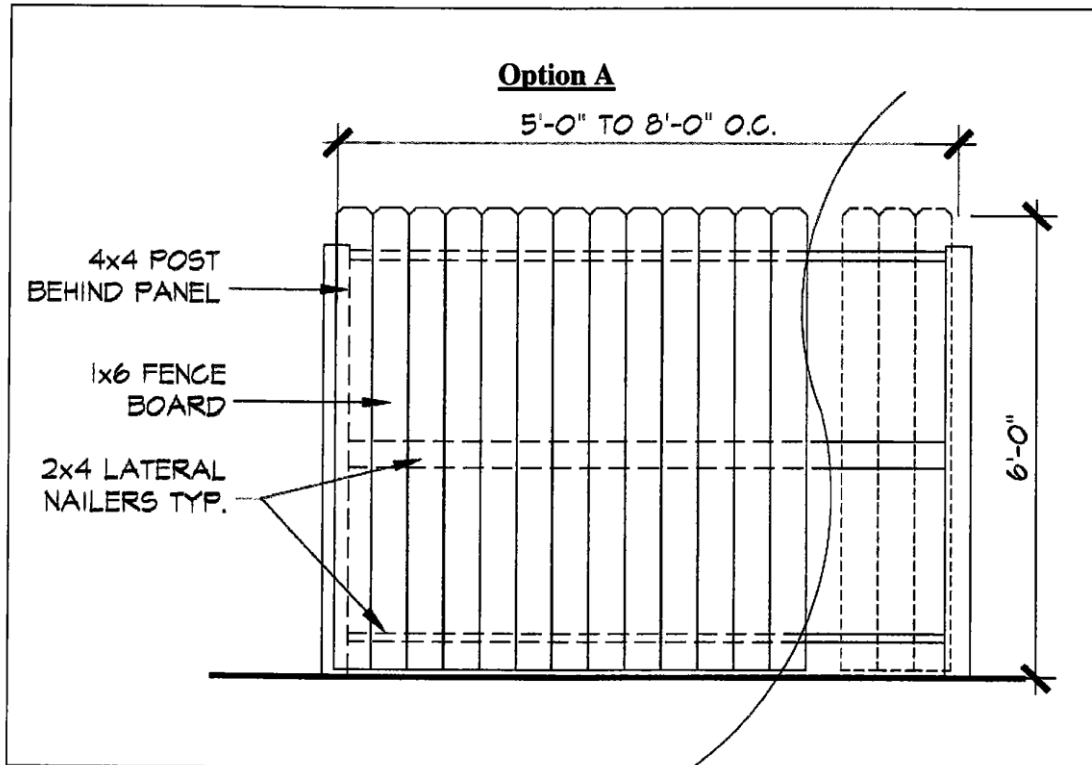

*Approved stains include the following from Sherwin Williams: SW 3503 White Birch, SW 3505 Yankee Barn, SW 3507 Riverwood, SW 3508 Covered Bridge, SW 3509 Baja Beige, SW 3521 Crossroads, SW 3540 Mountain Ash. Note: all stains are semi-transparent.